

PLANIMETERS AND INTEGRAPHS IN THE 19th CENTURY. BEFORE THE DIFFERENTIAL ANALYSER

MARIE-JOSÉ DURAND-RICHARD

ABSTRACT

When reading books on the history of computing, we are accustomed to find informations on arithmetical engines, and on the developments of the relation between logic and mathematics at the beginning of the 20th century. From a standpoint such as this, it is difficult to understand what is going on in scientific calculus between Babbage's analytical engine and the computers. This view of history simply neglects the importance of analog instruments. Certain of them, such as planimeters and integragraphs, designed for measuring surfaces, materialized the theoretical integral calculus, and gave results even when the calculus did not. First invented in the beginning of the 19th century, they were essentially developed after the theoretical legitimization of the polar planimeter by Jakob Amsler (1823-1912) after 1856. This small and practical instrument quickly spread amongst the engineers of European industrial countries. Integragraphs drew the curves giving the area for each point on the outline of the surfaces to be measured. They were manufactured as prototypes rather than on a large scale, and were not used to such an extent as planimeters.

More specifically in England, planimeters and integragraphs gained in importance with the particular implication of some engineers-physicists. And the initial system of a roller rolling on a cone or a disc was integrated into more complex apparatus. Lord Kelvin's (1824-1907) harmonic analyser used several systems (disc-sphere-cylinder) to draw different Fourier components of the periodic movement of the tides, and Kelvin devised a manner to build them in order to resolve differential equations. Several decades later, when technical problems were resolved, Douglas R. Hartree (1897-1958) followed Vannevar Bush (1890-1974) devising the differential analyser.

Keywords: Planimeter, integragraph, harmonic analyser, differential analyser.

When we read books¹ on the history of computing, we generally find information on arithmetical engines, and on the developments of the relation between logic and mathematics at the beginning of the 20th century. Typically, this kind of approach presupposes that nothing happened in the history of scientific calculations outside the arithmetical means of calculation, especially between Charles Babbage's conception² of the *Analytical Engine* (1834-55) and the development of computers after World War II. Among some of the more attentive historians of computing,³ a collective research program, "Les instruments du calcul savant",⁴ recently explored the whole range of methods and instruments which, from the 19th to the late 20th century, were extensively used by different scientific communities. It showed how graphical methods and mechanical analogue instruments could give numerical results which were required for astronomy, physics, and engineering, but which could not be obtained by theoretical means. In such cases, these special means of calculus superseded theory, as they gave better more accurate results.

Planimeters and integragraphs represented an essential part of these mechanical analogue instruments. Designed to obtain the areas of surfaces, they could measure the theoretical integrals under any curve, and gave results even when the integral calculus did not. The question of how to measure areas is a very old one, particularly for governing land, property and registries; thus, more than one million of mechanised planimeters were produced in the industrial countries of Europe from the 19th century to the 1970s, and they continue to be produced nowadays, essentially in Japan and the United States. They are still preferred to computers in some special situations,⁵ despite the fact they have been nearly forgotten in the history

¹ For instance, MICHAEL R. WILLIAMS, *History of Computing Technology* (IEEE Computer Technology Service, 1995), 2nd edition revised.

² ANTHONY HYMAN, *Charles Babbage, Pioneer of the Computer* (Princeton: Princeton University Press, 1982), pp. 164-210.

³ For instance, WILLIAM ASPRAY (ed.), *Computing before Computers* (Ames [Iowa]: Iowa State University Press), 1990. Electronic edition: <http://ed-thelen.org/comp-hist/CBC.html>.

⁴ This research program, directed by Dominique Tournès, was developed in Paris at REHSEIS (Recherches en Epistémologie et Histoire des Sciences et des Institutions Scientifiques, CNRS and Paris VII University), from 2003 to 2007. Website: <http://www.reunion.iufm.fr/Dep/matheuatiqes/calculsavant/>. A book is forthcoming on *Histoire du calcul graphique et graphomécanique*. I wish to express my gratitude to D. Tournès who involved in this project, and to Paolo Brenni (*Istituto e Museo di Storia della Scienza*, Firenze), president of the Scientific Instrument Commission, to have suggested to present some of our results for the XXVI *Scientific Instruments Symposium*, held September 6-11, 2007 in Cambridge MA (Harvard University and Massachusetts Institute of Technology Museum).

⁵ They are still in use for measuring, for instance, the surface of a tumor surface on a radio image, the growth of leaves in botany, a shoal of fish on a sonar image, or petroleum flow in pipes.

of computing. Fortunately, important museums, such as the *München Deutsches Museum*,⁶ the *Science Museum* in London,⁷ and the *Conservatoire National des Arts et Métiers* in Paris,⁸ possess rich collections of these instruments, as they were often registered there for patents.⁹

Their development kept pace with that of industry and with the growing importance of the role played by engineers during the same period: engineers' works established an essential social link between university and industry, and a conceptual link between theoretical and practical knowledge. The distinctive development of these devices seems to be strongly linked with these specific relationships as they arose in various countries. Essentially, the mechanical integration principle invented for the planimeter was later imbedded in more complex machines, of which the differential analyser was to be the most important.

1. THE MECHANISATION OF THE INTEGRATING PROCESS

The first use of mechanical integrating instruments is associated with those who combined a fair knowledge of integration theory with that of the craftman's workshop, where there often arose a need for serious and numerous calculations.

1.1. *The mechanisation of the approximation method*

To obtain the area inside an irregular curve, a common approximation method existed, that could be managed by hand. This triangulation

⁶ Professor Joachim Fischer, gave his expertise in the preparation of the exhibition (n. 5). JOACHIM FISCHER, "Instrumente zur mechanischen Integration, Ein Zwischenbericht", *Brückenschläge, 25 Jahre Lehrstuhl für Geschichte der exakten Wissenschaften und der Technik an der Technischen Universität Berlin, 1969-1994*, edited by H.W Schütt, B. Weiss (Berlin: Verlag für Wissenschafts und Regionalgeschichte Dr. Michael Engel, 1995), pp. 111-156; JOACHIM FISCHER, "Instrumente zur Mechanischen Integration II. Ein (weiterer) Zwischenbericht", *ChemieKultur-Geschichte. Festschrift für Hans-Werner Schütt anlässlich seines 65. Geburtstages*, edited by A. Schürmann, B. Weiss (Berlin/Diepholz: Verlag für Geschichte der Naturwissenschaften und der Technik, 2002), pp. 143-155.

⁷ I am very grateful to Jane Wess who made the Archives of the *Science Museum* in London available to Dominique Tournès and I.

⁸ The *Conservatoire National des Arts et Métiers* (CNAM) possesses a great deal of planimeters and integragraphs, usually kept in stores, and therefore unfortunately too rarely shown. The research program "Les instruments du calcul savant" led to an exhibition of these instruments, "Venez prendre l'aire!" (21th of november 2007-28 of april 2008), which can be now virtually consulted on its Website (cit. note 4). The commissioners of the exhibition were Loïc Petitgirard and Thierry Lalande for the CNAM, Dominique Tournès and myself for REHSEIS.

⁹ Investigations are still carried out about the other places and museums where to find these instruments can be found.

method inscribed more simple surfaces inside the curve. Since the 17th century, practitioners began to use a rectangular frame named a “hair planimeter”, because of the horsehairs that made up the median bases of parallel-based trapezoids of the same height. A measuring compass was used to span the medians b_1, \dots, b_n of the trapezoids, which were added graphically on a straight line. Their sum was then multiplied by the value of h , which was known to the user (Fig. 1a).

Georg Zobel and Joseph Müller mechanised this device in 1814 in Germany. It was at once manufactured by Sebastien Müller in Ebersbach for the Royal Cadastre Survey.¹⁰ A moving carriage sustained a rolling wheel, which measured and added the medians. The surface whose area had to be measured was placed under a glass plate on which striations are regularly spaced by the trapezoids width. The user had to lift the carriage as he moved it from one median to the other. The wheel recorded the sum of their lengths, and the measured area was directly read onto the wheel with the required units (Fig. 1b).

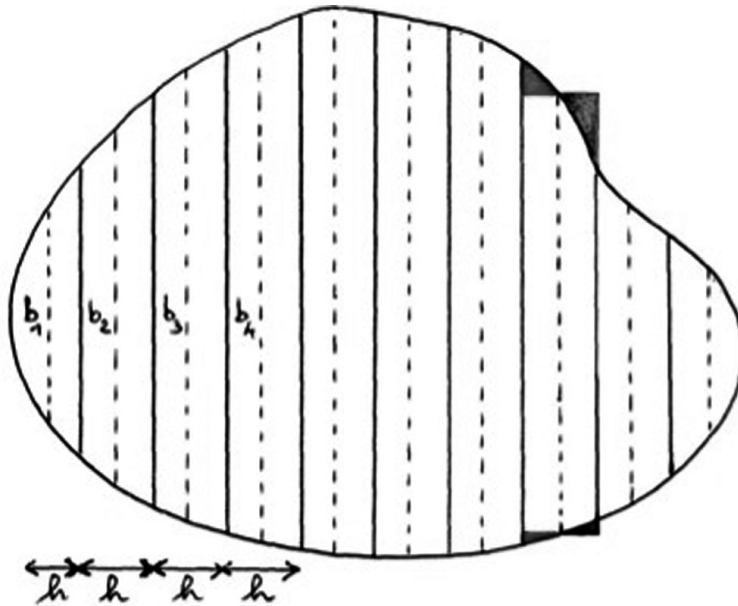

Fig 1a. Approximated area: $A = (b_1 + b_2 + \dots + b_n) \cdot h$.

¹⁰ FRIEDRICH L. BAUER (ed.), *Informatik, Führer durch die Ausstellung* (München: Deutsche Museum, 2004), pp. 52-78.

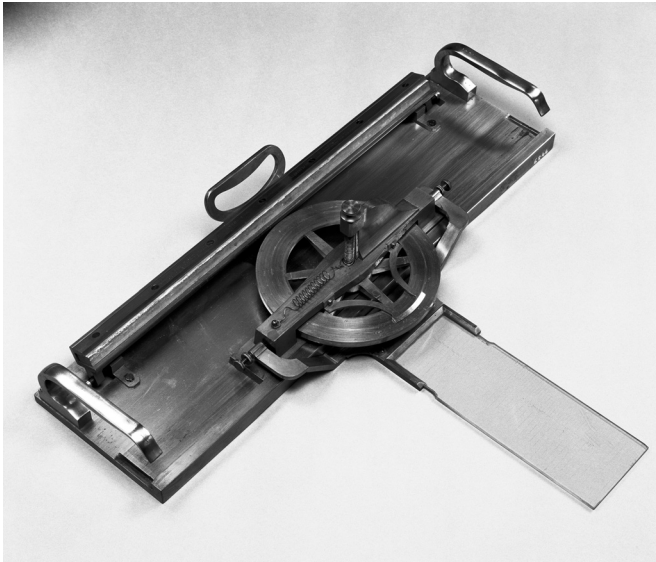

Fig 1b. Hair planimeter, system Beuvière, 1844. Maker Niggli, Paris, Inv. 06245-0000. Musée des Arts et Métiers - CNAM, Paris, photo M. Favareille.

Other instrument makers soon manufactured hair planimeters: A. Beuvière (1845) and E.F. Hamann (1855) in Paris, J. Perfler and R. & A. Rost in Vienna towards 1850.

1.2. *The orthogonal planimeters as mechanisation of integration theory*

When the height of the trapezoids vanishes, the approximate area becomes the exact area. And, as we now know and write ever since Newton's and Leibniz's invention of the infinitesimal calculus in the 17th-century, the area between the curve whose equation is $y = f(x)$, the X-axis and the two straight lines with equations $y = 0$ and $y = x$, is given by the formula:

$$A = \int_0^x y \cdot dx = \int_0^x f(x) \cdot dx$$

But this formula requires that the user knows the equation of the curve and knows how to integrate it, which is not always the case. Consequently, when the contour line of the surface is a very irregular one, this formula is not suitable. So, numerical measurements provided by the orthogonal planimeters were more efficient.

1.2.1. The cone-wheel planimeter

The first of these orthogonal planimeters was a cone-wheel planimeter. Its invention occurred simultaneously in several European countries in the first half of the 19th-century, but its manufacturing was difficult at first. The cone-wheel planimeter was independently invented in 1814 by the Bavarian engineer Johann Martin Hermann (1785[?]-1841), land surveyor at the Cadastre and Taxes Office, and in 1825 by the Italian Tito Gonnella (1794-1867), who taught mathematics at the faculty of Arts in Florence. In Switzerland, then already renowned for excellent craftsmanship, the mechanic Johannes Pfäffli (1802-1828), and, following his death, Heinrich Rudolf Ernst (1803-1863) began to build one for Johannes Oppikofer (1783-1864), which was presented to the *Berner Naturforschende Gesellschaft* in 1829. Notwithstanding Gonnella's publications¹¹ and his invention of the device, it remained unnoticed until Ernst made it widely known in Paris when he won the *Prix Montyon* (1837) with the new copy he presented in 1834.

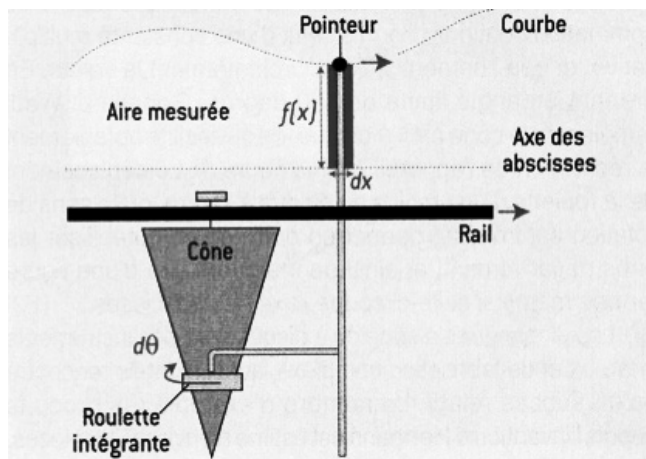

Fig. 2a. $\int_0^x y \cdot dx = \int_0^x f(x) \cdot dx$ gives the area under the curve $y = f(x)$.

¹¹ TITO GONNELLA, "Teoria e descrizione d'una macchina colla quale si quadrano le superficie piane", *Antologia*, 1825, 18: 122-129 + 1 pl. 6 figs. ID., *Opuscoli matematici nei quali si tratta I. di alcuni perfezionamenti del telescopio newtoniano; II. delle formule che determinano rigorosamente l'andamento dei raggi luminosi a traverso d'un sistema qualunque di lenti; III. d'una macchina per quadrare le figure piane* (Firenze: Tipografia e fonderia di Giovanni Mazzoni, 1841).

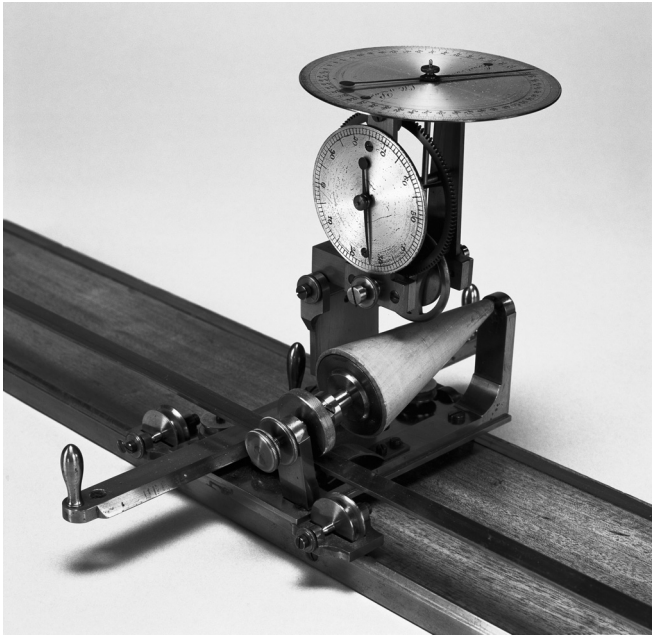

Fig. 2b. The cone-wheel planimeter, 1835, Maker: Ernst, Paris. Inv.02624-0000. Musée des Arts et Métiers - CNAM, Paris, photo M. Favareille.

A pointer is moved along the curve $y = f(x)$. As it moves along the x-axis, it drives the cone's revolving on its own axis, and at the same time drives the rolling of the orthogonal wheel. The pointer's movement along the y-axis makes the wheel's height change on the cone, this height being so maintained at the distance $y = f(x)$ from the summit of the cone (Fig. 2a). Hence, each movement of the pointer transmits a rotation to the wheel, whose angle was measured by $d\theta = f(x) \cdot dx$. So, the summation of these angles gives the required integral. The planimeter was named "orthogonal" because of the two orthogonal directions of the wheel's movements.

The device's fame was helped by the interest of the learned engineers Jean-Victor Poncelet¹² (1788-1867), Arthur-Jules Morin (1795-1880), Léon Lalanne (1811-1892) and by a paper written by the Count de Lambel in the 1841 *Bulletin de la Société d'Encouragement pour l'Industrie Nationale*. Several models exist in Paris, London (Figs. 2b and 2c), and also in Aarhus (Denmark).

¹² The same Poncelet is rather famous as the founder of projective geometry. JEAN-VICTOR PONCELET, *Traité ds propriétés projectives des figures*, 2 vols. (Paris: Gauthier-Villars, 1822).

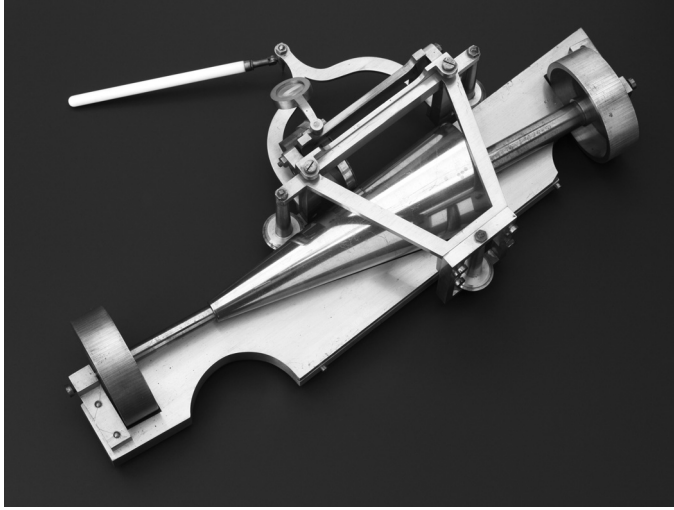

Fig. 2c. The cone-wheel planimeter, Sang, 1851. Inv. 1924-556. Science Museum London SSPL.

1.2.2. The disc-wheel planimeter

As Gonnella had already indicated in 1825, the cone did not play any specific role in the process. Thus, it could be replaced by a disc, which is considered as a cone whose vertex angle was 180° . This device was easier to manufacture and the disc made possible to account for negative ordinates for the curve. This idea, first proposed by Gonnella in 1825, was reinvented in 1849-50 by the Swiss engineer Kaspar Wetli (1822-1889) and was later heavily involved in the construction of railroad lines. Successively modified for precision and usefulness by Simon Stampfer¹³ (1790-1864), and by the astronomer Peter Andreas Hansen (1795-1874) in Seeberg/Gotha, the device was manufactured and commercialized with immediate success in the 1850s by the polytechnic workshop of Georg Christoph Starke (1794-1865) in Vienna, and later by Hermann Ausfeld (Fig. 3a).¹⁴ Approximately five hundred items were in circulation at that time.

¹³ SIMON STAMPFER, "Über das neue Planimeter des Ingenieurs Caspar Wetli zu Zürich", *Sitzungsberichte der kaiserlichen Akademie der Wissenschaften in Wien. Mathematische-Naturwissenschaftliche Classe*, 1850, 4: 134-155 + pl. II. Id., "Ueber das neue Planimeter des Kaspar Wetli, Ingenieur im Kanton Zürich", *Diguler's polytechnischen Journal*, 1850, 116: 421-444 + pl. VI.

¹⁴ The *Hungarian Museum of Textile and Clothing industry* also possessed an item of this planimeter.

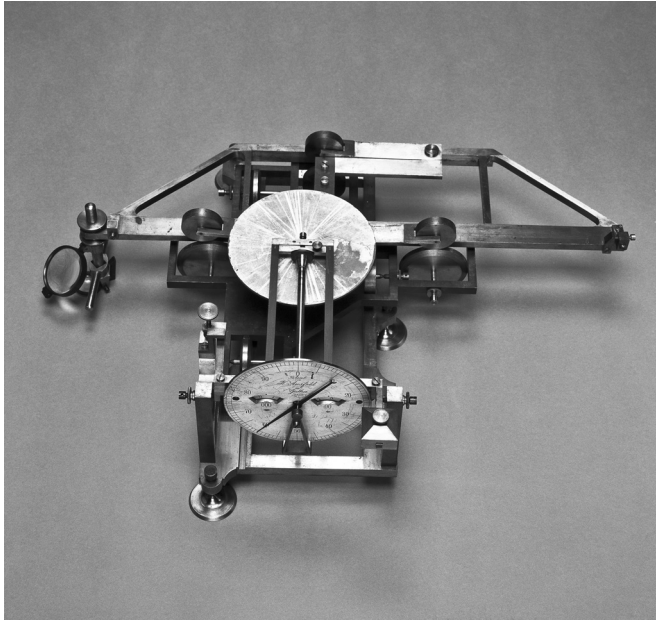

Fig. 3a. Disc-and-wheel planimeter, Wetli-Hansen type, Maker Ausfeld, 1851. Inv. 06340-0000. Musée des Arts et Métiers - CNAM, Paris, photo M. Favareille.

Therefore, regardless of whether a cone or a disk was used, the resulting integrating mechanism was an immediate translation of mathematical integration into mechanics.

2. INCREASING USES IN INDUSTRIAL EUROPEAN NATIONS

From these cone-wheel and disc-wheel planimeters, mechanical integration was developed in several directions, both technical and practical. And the new devices were involved in large state, or private, industrial projects, that extended now far beyond the Land Registry. Conversely, industrial progress made it possible to improve the mechanisation of the devices and their efficiency. Numerous examples illustrate these specific needs and advancements, from the determination vaults shape to investigation of moving systems – for instance in ballistics – or electrical problems. Planimeters were used in construction of roads, canals, railroads, to minimise the transportation of earth volumes in embankments and excavations. They replaced tables, diagrams and



Fig. 3b. Polar planimeter, Amsler (Schaffhausen), 1865. Inv. 08004-0000. Musée des Arts et Métiers - CNAM, Paris, photo M. Favarelle.

approximation quadrature methods in naval architecture problems.¹⁵ And whereas the engineering profession was diversifying the realm of mathematical applications, mechanical production was gaining in precision.

2.1. *The polar planimeter*

On the technical side, the polar planimeter, invented in 1854 and patented in 1855 by Jakob Amsler (1823-1912), gave mechanical integration its final breakthrough. Its construction and use were much simpler than for the preceding devices, and therefore it was less expensive. The underlying theory was more complicated, as the polar planimeter materialises Green's theorem, but Amsler's 1856 publication¹⁶ ensured the theoretical legitimacy of its success.

The pole of the instrument is maintained by its own weight in a fixed position on the drawing. The tracer pin was led once around the boundary

¹⁵ BRUNO ABDANK-ABAKANOWICZ, *Les intégraphes, la courbe intégrale et ses applications. Etude sur un nouveau système d'intégrateurs mécaniques* (Paris: Gauthier-Villars, 1886), pp. 73-133. The whole chapter V is devoted to these applications.

¹⁶ JAKOB AMSLER, *Ueber die mechanische Bestimmung des Flächeninhalts, der statischen Momente und der Trägheitsmomente ebener Figuren, insbesondere über einen neuen Planimeter* (Schaffhausen: Beck, 1856).

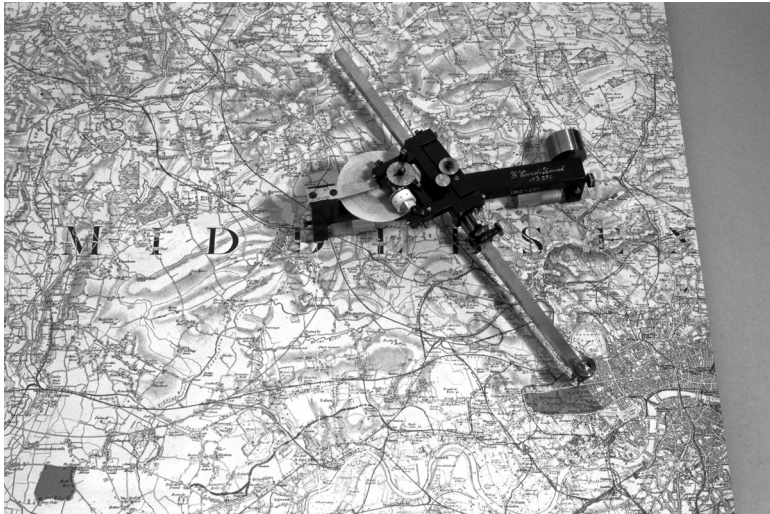

Fig. 3c. Precision planimeter, Hohmann 1876, Maker Coradi 1886. Inv. 1912-201. Science Museum London SSPL.

of the area to be measured. The integrating mechanism was constructed so as to keep a direction parallel to the tracer arm, and the rolling wheel totalises the infinitesimal areas. The tracer arm could be built longer, or with an adjustable length, so as to be adapted to various uses,¹⁷ and read with different unit lengths (Fig. 3b).

This simple and practical instrument quickly spread throughout the industrial nations of Europe, where it gave rise to numerous prototypes and precision models (Fig. 3c).¹⁸

2.2. The industrialisation process and the development of mechanical integration

On the practical side, the success of such devices also came from their numerous uses in the industrial command of machines. The disc-wheel mechanism was imbedded in many apparatuses intended to measure the power output of machines, whenever such a measure could amount to the

¹⁷ While preparing this paper, I discovered such a device decorating the window of a leather shop in Paris, 42 rue Saint Jacques, where it had been in use not long before to measure the surface of leather skins.

¹⁸ Professor Joachim Fischer recently made a gift to the CNAM of several current precision models, from Bayern (Haff) and Los Angeles (LASICO).

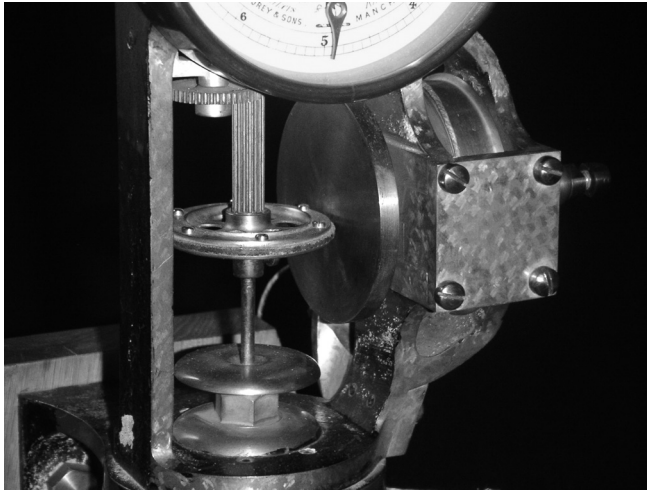

Fig. 4a. Pressure indicator with totalizer (detail), Ashton & Storey, Manchester, before 1885. Inv. 10612. Musée des Arts et Métiers - CNAM.

determination of an area inside or under a curve. For instance, this application holds in dynamometers which measure the work of the driving force in a tractor – the variations of the work produced being first registered on a curve whose integral is then taken. The analysis of steam engine power was the most important application, as it was the quintessential machine of the Industrial Revolution: the indicator diagram recorded the course of the piston moved by steam pressure, and the area of this diagram provided the force so produced. All totalizing instruments involved similar devices (Fig. 4a), for instance to measure the consumption of energy in industrial buildings with a central steam machine.

The development of these apparatuses was consistent with that of the mechanical science, and with the increasing needs of industry to measure the effects of machines both for productivity and billing.¹⁹ In England, their increasing use was evidenced in 1842 by a Report for the *British Association for the Advancement of Science* (BAAS). A committee was formed for the Construction of a Constant Indicator for Steam-Engine. Its president, Reverend Henry Moseley (1801-1872), professor of natural philosophy and astronomy, taught the theory of machines²⁰ to students of

¹⁹ JEAN-YVES DUPONT, “Evaluer la puissance des machines au XIX^{ème} siècle”, *La Revue du Musée des Arts et Métiers*, 2007, 48: 42-54.

²⁰ HENRY MOSELEY, *The Mechanical Principles of Engineering and Architecture* (London, 1843).

the department of engineering and architecture at King's College in London. In his report, he noted the pressure indicator by James Watt, the friction dynamometer from the engineer Baron Gaspard de Prony (1755-1839), and he attested that dynamometers were invented in France by Poncelet, with Morin directing their construction. In 1851, he reported too on the dynamometers²¹ presented at the *Great Exhibition of the works of Industry of all Nations*. This report, and the exhibited instruments, played a major role for the diversification of these devices in the second part of the 19th century.²²

2.3. Mechanical integration from the Great Exhibition

Held in Crystal Palace²³ London from the 1st of May to the 25th of October 1851, this event also recorded the first time Great-Britain had been involved in the sphere (ambigu comme area ici)/domain of planimeters. Among the thirty classes of exhibits at that impressive meeting, with machines such as the mechanical loom and the first iron ship *Great Britain*, the tenth class, entitled "Philosophical, Musical and Horological Instruments", was certainly not the most remarkable one of the event. Nevertheless, several planimeters were on display and awarded an "honourable mention".²⁴ N° 57 was a special item of Gonnella's planimeter, property of the Grand Duke of Tuscany, built for him to draw up the Ordnance Survey map of Elba island.²⁵ It was the most important award: the "Council Medal".²⁶

Independently of Continental developments, the Scottish engineer John Sang (1809-1887) presented his own manufactured "planometer, or self-acting calculator of surface" (Fig. 2c). The instrument was fitted out with a

²¹ The awarded dynamometer was manufactured by Clair in Paris. GÉRARD EMPTOZ, "Pierre et Alexandre Clair, constructeur de modèles", *Revue des arts et métiers*, 1993, 03: 04-10.

²² MARIE-JOSÉ DURAND-RICHARD, "Planimètres et intégraphes en Angleterre", Website *Les instruments du calcul savant* (cit. note 4).

²³ PAOLO BRENNI, "Dal Crystal Palace al Palais de l'Optique: la scienza alle esposizioni universali", *Memoria e Ricerca*, 2004, 17: 35-63.

²⁴ Were on display: the cone and wheel planimeters just referred above, and cone and disc planimeters from Wetli and Ausfeld. GREAT EXHIBITION, *Great Exhibition of Works of Industry of all Nations, 1851; official descriptive and illustrated catalogue* (London: Spicer Bros with W. Clowes and Sons, 1851), p. 304.

²⁵ Unfortunately, this item is lost nowadays. P. Brenni has been looking in vain for it for several years now.

²⁶ The cone-wheel planimeter which is on display at the *Science Museum* was manufactured by Clair (cit. note 15) in 1840, and sold to the museum in 1989 by P. Delehar, a seller of rare scientific instruments. Science Museum Archives.

vernier graduated in $1/100^{\text{th}}$ inch parts. Its displacement was no longer driven by a rail along the x -axis, but by two big rollers. Sang gave evidence of its better precision than that of the traditional method of scale. As long as two measures were produced by turning the figure by 180° , the instrument could provide comparative tests of accuracy. He also attested its use by Captain James, superintending officer of the Ordnance Survey of Scotland, prompting engineers, geometers, surveyors and architects, to follow in his path.²⁷

Visiting the Great Exhibition, James Clerk Maxwell (1831-79) admired these instruments. But he was “convinced that the combination of slipping and rolling [of the wheel on the cone or the disc] was a drawback on the perfection of the instrument”. He proposed “new forms for the rolling parts”, preferring the sphere to the wheel as the central element of the integrating mechanism. The devices he considered²⁸ directly fostered a lot of new systems, from new planimeters to the disc-ball-cylinder system by James Thomson (1822-92), the brother of William, later Lord Kelvin (1824-1907), both of them involved in the construction of the harmonic analyser (Fig. 6a).

Several reports gave evidence of the commitment of the *British Association for the Advancement of Science* in the field of mechanical integration. In 1894, the one by Olaus Henrici (1840-1918), a mathematician first educated as an engineer in Germany,²⁹ echoed many other papers published in academic and professional journals.

2.4. *An extension of planimeters: the integrators*

As soon as 1856, Amsler described and named “integrators” – also named ‘integraphs’ by other authors. They could provide the integrals of $f(x)^2$ and $f(x)^3$ which, respectively, denoted the static moment and the moment of inertia of the area under the curve $y = f(x)$ relative to the x -axis. These results were obtained mechanically, by a single measurement along the curve $f(x)$. These “moment planimeters”, as J. Fischer named

²⁷ JOHN SANG, “Description of a Platometer, an Instrument for Measuring the Areas of Figures drawn on Paper”, *Transactions of the Royal Scottish Society of Arts*, 1852, IV: 119-129 + Plate. In this paper, an enquiry indicated that Sang did not know anything about Gonnella’s planimeter.

²⁸ JAMES C. MAXWELL, “Description of a New Form of the Platometer, an Instrument for measuring the Areas of Plane Figures drawn on Paper”, *Transactions of the Royal Scottish Society of Arts*, 1855, VII: 420-429, p. 423.

²⁹ OLAUS HENRICI, “Report on planimeters”, *Report of the Sixty-fourth Meeting of the British Association for the Advancement of Science* (London: Murray, 1894), 6: 496-523.

them, were already exhibited at the Paris 1867 Exhibition, as they were commercially manufactured by Amsler in Schaffausen some time earlier.

But the 1880s represented a turning point for mechanical integration instruments, where the devices gained both precision and complexity. Essentially in Great-Britain, these devices gave evidence of specific relationships between some physicists and engineers, who invested their knowledge of the industrial world to make more efficient researches focused on mechanical means of resolving differential equations.

The engineer, physicist and inventor Henry Selby Hele-Shaw (1854-1951), designed an integrator specially conceived to avoid the slipping of the wheel. Professor of engineering of the new founded universities in Bristol (1881) and Liverpool (1885), he was a successful pioneer of engineering education, and he was appointed by the Secretary of State for the Colonies to organise there the whole Technical Education in Transvaal.³⁰ His first instrument was an integrating anemometer, built after the Tay Bridge disaster (1879) to give engineers a more accurate knowledge of wind loading on bridge structures. His investigations on the known types of integrators and their different sources of error led him to a new integrating system, where the recording rollers were set in motion on ground glass spheres revolving on a vertical axis by celluloid rolling cylinders (Fig. 4b). It was built in Zürich by Gottlieb Coradi (1847-1929), the famous high precision instruments maker, trained at Starke and Kammerer's workshops in Vienn, as he had just opened his firm at Zürich in 1880. Hele Shaw's publications on the subject were written for the different scientific societies concerned with integrating problems.³¹ In the 1890s, he produced important reports for the BAAS on the methods of Graphical Calculus in Great-Britain,³² in order to answer to its important development on the Continent.³³

³⁰ H.L. GUY, "Henry Delby Hele-Shaw, 1854-1941", *Obituary Notices of Fellows of the Royal Society*, 9 vols., Vol. 3 (London: Harrison & Sons, 1932-1954), pp. 790-811.

³¹ HENRY S. HELE-SHAW, "Mechanical Integrators", *Minutes of the Proceedings of the Civil Engineers*, 1885; "Theory of continuous calculating machines", *Philosophical Transactions of the Royal Society*, 1885; *Mechanical integrators, including the various forms of planimeters* (New York: Van Nostrand, 1886).

³² ID., "First report of the Committee, consisting of Mr W.H. Preece (Chairman), Professor H.S. Hele Shaw (Secretary), Messrs B. Baker, W. Anderson, and G. Rapp, and Professors J. Perry and R.H. Smith, appointed to report on the development of graphic methods in mechanical science", in *Report of the fifty-ninth Meeting of the BAAS, held at Newcastle-upon-Tyne in september 1889* (London: John Murray, 1890), pp. 322-327. ID., "Second Report on the development of graphic methods in mechanical science", in *Report of the sixty-second Meeting of the BAAS, held at Edinburgh in september 1892* (London: John Murray, 1893), pp. 373-531. ID., "The development of graphic methods in mechanical science. Third Report", *Report of the Sixty-*

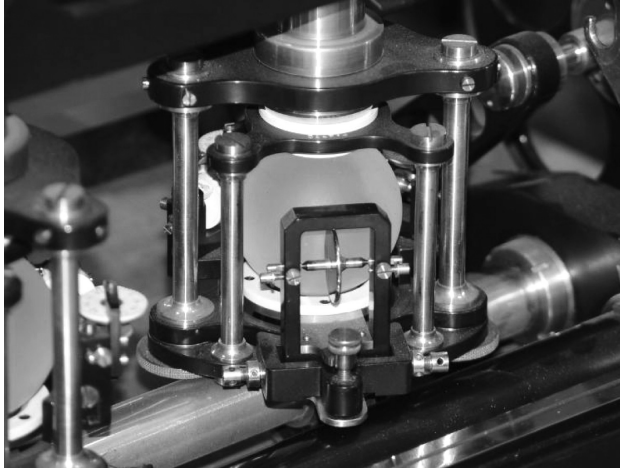

Fig. 4b. Hele-Shaw integrating mechanism avoiding slipping. Manufacture: Coradi. Here on Coradi's harmonic analyser. Bassin d'essais des carènes, Ministère de la défense, Photo: D. Monti.

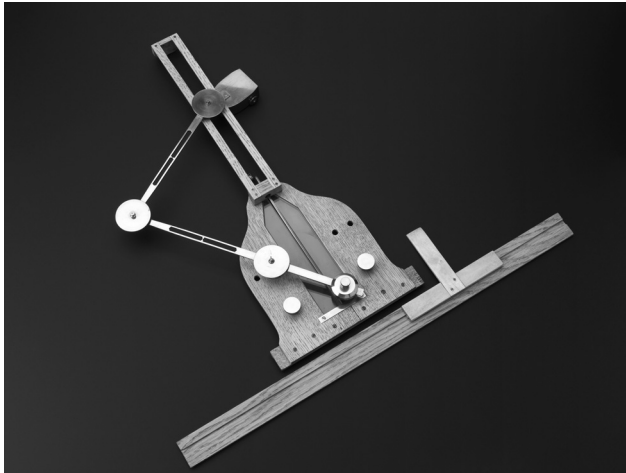

Fig. 4c. Boy's Curve drawing integrator. Inv. 1917-116. Science Museum London SSPL.

Third Meeting of the BAAS, held at Nottingham in september 1893 (London: John Murray, 1894), pp. 573-613.

³³ DOMINIQUE TOURNÈS, "Pour une histoire du calcul graphique", *Revue d'histoire des mathématiques*, 2000, 6: 127-161. EAD., "Junius Massau et l'intégration graphique", *Revue d'histoire des mathématiques*, 2003, 9: 181-252. EAD., "L'intégration graphique des équations différentielles ordinaires", *Historia Mathematica*, 2003, 30: 457-493.

2.5. A more dynamical involvement of integrating mechanism: the integraphs

With the integraph, as the user followed $y = f(x)$ on the initial curve, the integral curve was directly drawn on the same paper. The underlying principle relied upon the fundamental property that the inclination of the tangent of the integral-curve equals the ordinate of the initial one (Fig. 5a). It was conceived by both³⁴ the engineer Bruno Abdank-Abakanowicz (1852-1900) at Lwów (Poland) in 1876, and by the engineer and physicist Charles Vernon Boys (1855-1944), at London in 1881. Both of them had their devices manufactured by Coradi. He and Amsler-Laffon were significant of the same level of mechanisation and engineering contacts all through Europ at the end of XIXth century.

Abdank-Abakanowicz was taught in Lwów by the mathematician Wawrzyniec Smurko's (1842-1889), himself a famous instrument maker.³⁵ When he moved in France in 1881, he worked as an expert in electrification for the French government, especially in Lyon. His integrating mechanism was a continuous knife-edge screw drawing directly

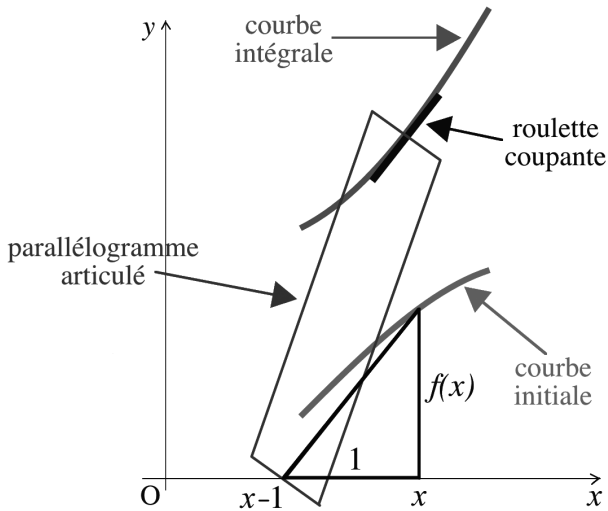

Fig. 5a. The principle of integraph.

³⁴ ABDANK-ABAKANOWICZ, *Les intégraphes* (cit. note 10), p. VIII and p. 49.

³⁵ ZOFIA PAXLOIKOWSKA-BROZEK, "On mathematical life in Poland", in C. GOLDSTEIN – J. GRAY – J. RITTER (éds.), *L'Europe Mathématique – Mythes, histoires, identités. Mathematical Europe – Myth, History, Identity* (Paris: Eds. M.S.H, 1996), pp. 289-301, p. 293.

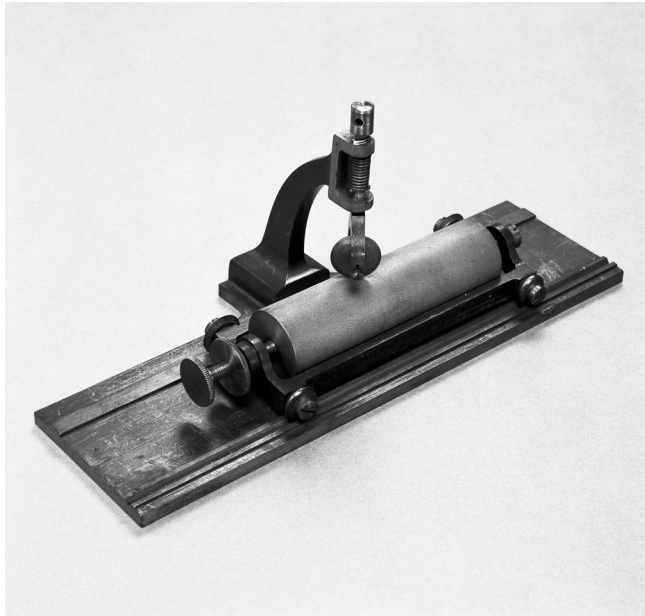

Fig. 5b. The continuous screw of Abdank-Abakanowicz, 1900. Inv. 13300-004. Musée des Arts et Métiers - CNAM, Paris, photo M. Favareille.

the integral curve on the cylinder where the paper is rolled (Fig. 5b). He conceived several different one-of-a-kind prototypes when still in Lwów. At the 1883 Vienna Exhibition, he met David Napoli (1840-1890), the chief inspector and director of the workshop of the French Eastern Railway. Their collaboration in Paris led to the production of an integrator of which the transfer of direction was achieved by a cogwheel mechanism, made by Barbier's workshop. But this model was completely overshadowed by the integrator with a linkage parallelogram, manufactured in Zurich by Coradi (Fig. 5c).

In 1881, Charles V. Boys,³⁶ graduated from the *Royal School and Mines*, presented to the *Physical Society of London*, along with a particular polar planimeter, his "curve drawing integrator"³⁷ manufactured in London by

³⁶ LORD RAYLEIGH, "Charles Vernon Boys (1855-1944)", *Obituary Notices of the Royal Society* (London: Harrison & Sons, 1932-1954), 9 vols., 4, 771-788. This obituary notice just alludes to his integrating instruments.

³⁷ CHARLES VERNON BOYS, "An Integrating Machine", *The London, Edinburgh and Dublin Philosophical Magazine and Journal of Science*, 1881, 11: 342-348 + plate VIII.

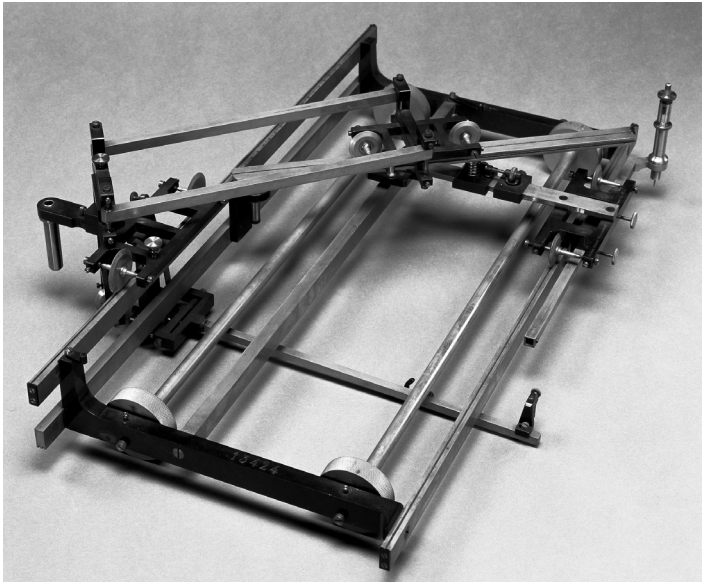

Fig. 5c. Integrator with transfer of direction by a linkage parallelogram. Abdank-Abakanowicz, Maker Coradi 1901. Inv. 13242-0000. Musée des Arts et Métiers-CNAM, Paris, photo M. Favareille.

M. Hilger, Tottenham Court Road. This integrating machine was first conceived for pedagogical purposes when he was demonstrator in physics at the *Normal School of Science* in South Kensington.³⁸ But, as Abdank-Abakanowicz suggested it, he was more interested by the industrial applications of his work, and he went on to build remarkable indicators for steam engines and counters for electrical energy. As a Metropolitan Gas Referee, he later designed a calorimeter which he named a “thinking machine” because it could measure heat variations, using an imbedded disc-ball-cylinder integrator, that is the basic system of harmonic analyser.

Clearly, integrometers, integrators, and analysers were conceived by, and for, engineers directly involved in the applications of physics, or who were physicists by themselves, implicated in the technical development of main scientific projects,³⁹ for the 19th century industrial nations.

³⁸ Id., “On Integrating and other Apparatuses for the measurement of mechanical and electrical forces”, *The London, Edinburgh and Dublin Philosophical Magazine and Journal of Science*, 1882, 13: 77-95 + plates III-IV; Id., “Apparatus for calculating efficiency”, *Proceedings of the Physical Society*, 1882, V: 8-35.

³⁹ DAVID BAXANDALL and JANE PUGHS, *Catalogue of the Collections in the Science Museum, Calculating Machines and Instruments* (London: Science Museum, 1975), p. 55.

3. FROM INSTRUMENTS TO MACHINES: THE ANALYSERS

The association of several integrating mechanisms in more complex machines led inventors to solve more difficult differential equations. It also strongly suggested the possible substitution of “metal to brain”,⁴⁰ as suggested by Lord Kelvin in 1878.

3.1. *The harmonic analyser*

From 1861, the engineer James Thomson was concerned with developing mechanical means of use in meteorological observatories so as to obtain integrations connected with wind motions. His brother, the physicist William Thomson – later Lord Kelvin – was also concerned by engineering problems, as director of the Atlantic Telegraph & Co since 1856, and of the firm Kelvin & White, where were manufactured numerous precision instruments.⁴¹ James conceived the system “disc-ball-cylinder” which gave the integral of a product of two functions (Fig. 6a). It would be the central element in the harmonic analyser of Lord Kelvin in 1876 (Fig. 6c), designed first for analysing tides.⁴² Applying Fourier analysis, the harmonic analyser associated eleven such systems and could give the first harmonics of the tides previously registered by a tide gauge on the coasts of south England and France, and as far as Bombay in India and Fort Point in California (Fig. 6b). This enabled the tide predictor to re-compose them in a time span not exceeding four hours, thus predicting the level of water at any time in a given harbour throughout the year. These three devices were used by Great-Britain, India and other naval countries. Another harmonic analyser, with six integrating systems, was manufactured by Munro and set up in the Meteorological Office at Kew Observatory, where James suggested to use it for daily variations of temperature and barometrical

⁴⁰ LORD KELVIN, “Presidential Address”, *Report of the forty-first Meeting of the British Association for the Advancement of Science, held at Edinburgh in 1871* (London: John Murray, 1872), p. LXXXVI.

⁴¹ CROSBIE SMITH – M. NORTON WISE, *Energy and Empire: a biographical study of Lord Kelvin* (Cambridge: Cambridge University Press, 1989).

⁴² JAMES THOMSON, “An Integrating Machine having a new Kinematic Principle”, *Proceedings of the Royal Society*, 1876, 24: 262-266. WILLIAM THOMSON (Lord Kelvin), “An Instrument for calculating $(\int \Phi(x)\Psi(x)dx)$, the Integral of the Product of two given Functions”, *Proceedings of the Royal Society*, 1876, 24: 266-270. ID., “Harmonic Analyser”, *Proceedings of the Royal Society*, 27 (1878), 371-373. Reprint in WILLIAM THOMSON – PETER GUTHRIE TAIT, *Treatise on Natural Philosophy*, 2 vols. (Cambridge: Cambridge University Press, 1879), vol. 1, part 1, 505-508. The French translation of these texts can be found on the Website “Les instruments du calcul savant” (cit. note 4).

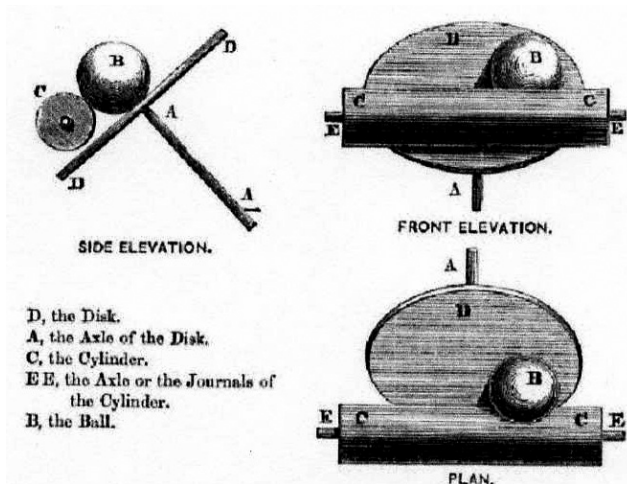

Fig. 6a. The disc-ball-cylinder system of James Thomson, 1876.

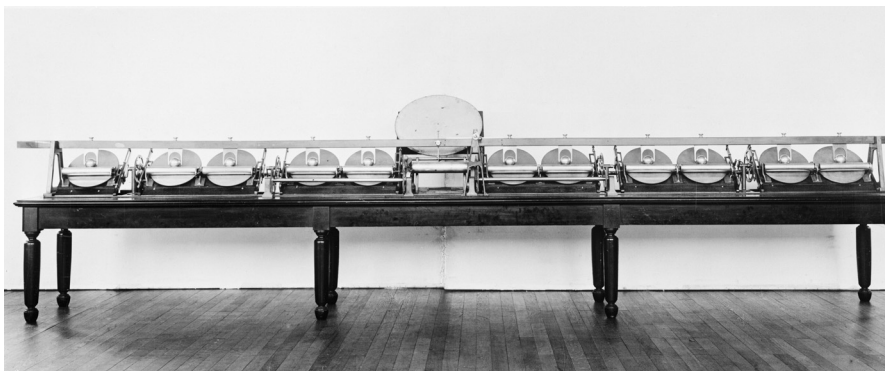

Fig. 6b. Harmonic Analyser of Lord Kelvin, 1876, Inv. 1896-60. Science Museum London SSPL.

pressure, as well as the components of wind velocity, terrestrial magnetic force, and electrical air potential.

Other harmonic analysers will be manufactured, and set out with the spherical rollers systems: Henrici's one, made by Coradi in 1894, John Harvey's one, made by E.A. Nehan in 1929, and the one bought by the French Navy in 1930, which worked until the 1960s.⁴³

⁴³ This one was especially investigated by Dominique Monti in a seminar of the project "Les instruments du calcul savant" (cit. note 4).

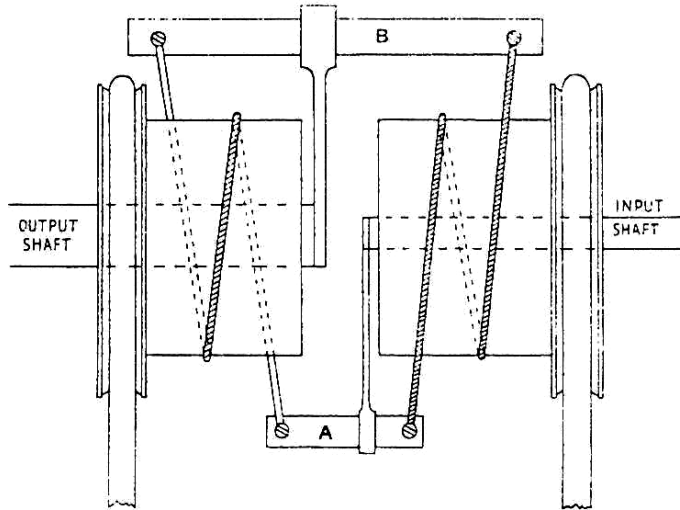

FIG. 4. Principle of torque amplifier.

Fig. 6c. Diagram of the torque amplifier. Hartree, 1938.

Synthetical books published at the beginning of the 20th century gave evidence of the continuous interest of these devices – instruments and engines – for the resolution of differential equations.⁴⁴

3.2. *The differential analyser*

Once he had conceived his harmonic analyser, Lord Kelvin contemplated associating two integrating devices for the mechanical integration of linear differential equations of the second order by successive approximation, including those with variable coefficients.⁴⁵ But the precise mechanical link between the two and their mechanical drive remained difficult to execute because the loads on the various shafts became so heavy that the wheels would slip.

Facing electrical problems, Vannevar Bush (1890-1974), from the Massachusetts Institute of Technology, thought of the torque amplifier

⁴⁴ HENRI DE MORIN, *Les appareils d'intégration, intégrateurs simples et composés, planimètres, intégromètres, intégraphes et courbes intégrales, analyse harmonique et analyseurs* (Paris: Gauthier-Villars, 1913).

⁴⁵ WILLIAM THOMSON (Lord Kelvin), "Mechanical Integration of linear differential equations of the second order with variable coefficients", *Proceedings of the Royal Society*, 1876, 24: 269-271.

– on the same principle as the capstan – which was set up in his differential analyser,⁴⁶ and quickly produced in Great Britain by the physicist Douglas Rayner Hartree (1897-1958), then Beyer Professor of Applied Mathematics at Manchester University. Hartree was mainly concerned with computational methods applied in the resolution of differential equations in ballistics, atomic physics and quantum mechanics.⁴⁷ A first model was built in Manchester by the Metropolitan-Vickers Electrical Company Ltd in 1935, a second one for the Cambridge Mathematical Laboratory.⁴⁸ The size of the machine makes manifest the change of scale that had occurred since Kelvin's harmonic analyser (Fig. 6d). By the 1940s, the differential analyser was the most important machine used in scientific calculations all over the world. Several other items existed in Great-Britain and in Europe.

Analogue and digital computers cohabited up to the 1950s. An analogue computer manufactured in 1958 still worked on a disc-cylinder integrating



Fig. 6d. Differential Analyser, Douglas R. Hartree. Inv. 1974-597. Science Museum London SSPL.

⁴⁶ VANNEVAR BUSH, "The Differential Analyzer. A New Machine for Solving Differential Equations", *Journal of the Franklin Institute*, 1931, 212: 447-488.

⁴⁷ CHARLOTTE F. FISCHER, *Douglas Rayner Hartree: His Life in Science and Computing* (New Jersey: World Scientific Pub Co, 2003).

⁴⁸ DOUGLAS R. HARTREE, *Calculating Instruments and Machines* (Urbana: The University of Illinois Press, 1949).

mechanism.⁴⁹ The organising plans of these machines, associated with each differential equation resolution, was an essential part of the reflexion which led physicists, engineers and mathematicians to think of connecting such machines in terms of Boolean algebra.⁵⁰

CONCLUSION

If the manufacture of planimeters and integragraphs was first concentrated in those countries in which an important clock and watchmaking industry was already established, other developments took place elsewhere. All the productions mentioned above, even those more isolated and now missing – such as planimeters by Josef Stadler, at Eisenerz, in 1855; by Giere, at Fürth; by Decher, at Augsburg in 1856; by Bleranovski and Bouniakovsky, in 1852 and 1856, and later A. Krylov⁵¹ in 1908 at Saint-Petersburgh – demonstrated the significant circulation of technical knowledge linked to industrial development taking place within European countries in the 19th-century. The manufacturing of these devices was pursued in the 20th-century, as it can be seen in the catalogues of Arkon firm in 1928 and Allbrit firm in 1960.

Analogue instruments have been neglected by history of science, largely because of a common retrospective view of history. Moreover, the production of these devices locate them closer to the history of technology as the history of theoretical science, even if they played a fundamental role in helping to solve differential equations.⁵² The practice and use of devices for integration was part of the technical and scientific systems of the time, which essentially sought to study material nature. That was the case until thoughts on these topics were directed towards the organisation of calculus on analogue computers, paving the way for later digital calculus.

⁴⁹ On display at the Science Museum London, “Mechanical Analogue Computer”, Air Trainers Links Ltd, 1958.

⁵⁰ CLAUDE E. SHANNON, “A Symbolic Analysis of Relay and Switching Circuits”, *Transactions of the American Institute of Electrical Engineering*, 1938, 57: 713-723, reprint in Id., *Collected Papers*, edited by James Alexander Sloane, Aaron D. Wyner (New York: IEEE Press, 1993), pp. 471-495. CLAUDE E. SHANNON, “Mathematical Theory of the Differential Analyzer”, *Journal of Mathematics and Physics*, 1941, 20: 337-354, reprint in Id., *Collected Papers*, pp. 496-517.

⁵¹ ALEKSEI NILOLAEVICH KRYLOV, “Sur un intégrateur des équations différentielles ordinaires”, *Bulletin de l'Académie impériale des sciences de Saint-Petersbourg*, 1904, 20: 17-37.

⁵² THORNTON CARL FRY, “The use of the integragraph in the practical solution of differential equations by Picard’ method of successive approximations”, *Proceedings of the International Mathematical Congress held in Toronto, August 11-16, 1926*, edited by John Charles Fields, vol. 2 (Toronto: The University Press, 1928), pp. 407-428. DOUGLAS R. HARTREE, “The mechanical intergration of differential equations”, *The Mathematical Gazette*, 1938, 22: 342-364.